

Chipper, PTO - Model 624

4" Capacity



The Model 624, is a 4" capacity chipper with a large 4" x 5" infeed opening. Clear, debris curtain strips help protect the user from fly back of material. This unit utilizes, 1/2" thick x 7-1/4" long x 4" wide, Double Edge, chip blades and a 1/2" thick, reversible, sharpenable, and replaceable bed knife, for consistent chip size and chipping capabilities of even those small, viney, stringy, messy jobs! 360 degree Exhaust Chute, and Easy Adjust Exhaust Flap. No tools are required to adjust the exhaust flap or the exhaust chute. Full size PTO shaft and cover is supplied with the unit. 540PTO RPM recommended.



Only 16 HP Required @ the PTO!



Large 4" x 5" infeed opening, means less pruning and trimming
Clear debris curtain strips help protect the user from fly back of material.

3/4" Thick x 22-1/8" Diameter, 130 LB Impeller, with 4-welded and gusseted paddles for better chip discharge & air flow. 2 - 1/2" Thick, double-sided, chip blades, segmented into 2-knife pockets. Easy access to blades through 7-gauge thick steel impeller housing. 4 - Bolt, cast iron, self-aligning, greaseable bearing. Replaceable, Sharpenable, Adjustable steel Bed Knife.



Quality of Workmanship, Innovative Design, Built to Last!

Salsco, INC.
LEADER BY DESIGN

SPECIFICATION AND OPTIONS - MODEL 624PTO GRAVITY FEED WOOD CHIPPER

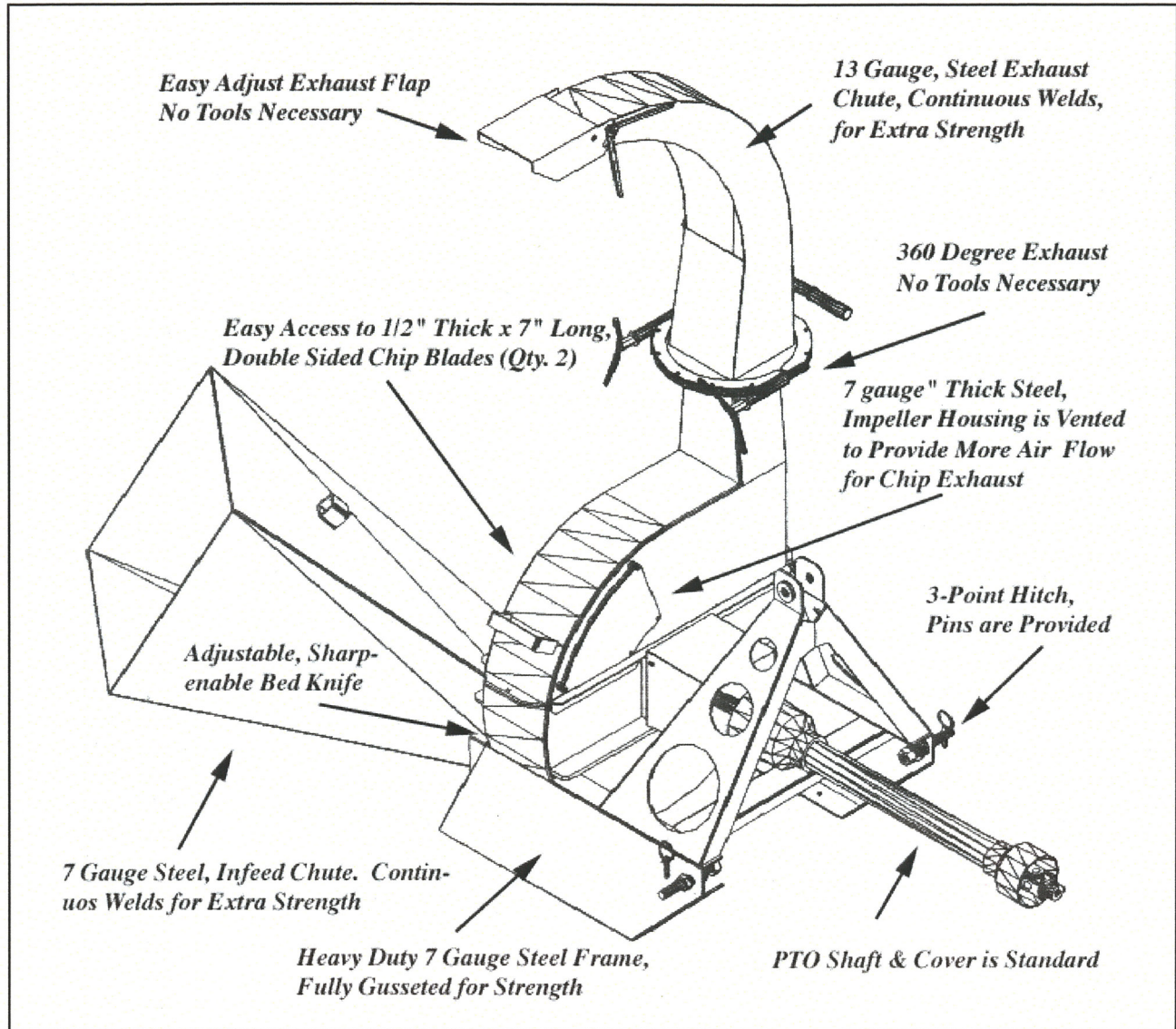

DIMENSIONS

LENGTH: 4' 7" **HEIGHT:** 5' 10"
WIDTH: 4' **WEIGHT:** 525 LBS.

Specifications & Options Subject to Change Without Notice

REV. 1/2013

MANUFACTURER OF OUTDOOR POWER EQUIPMENT

Products for Turf & Lawn care, Rental, Construction, Tree Care, Wood Processing, Nursery & Farm Industries

Other Salsco Equipment

3-1/2" - 18" Capacity, Gas, Diesel, & P.T.O., Wood/Brush Chippers
Chipper Shredder Vacuums - Tailgate & Truckloader Vacuums
Shaving Mills from 14 yds. - 48 yds Per Hour, Electric & Diesel Powered
Gas & Electric Greens Rollers - Bale Wrappers & Bale Handlers

Salsco, INC.
 LEADER BY DESIGN

105 School House Road
 Cheshire, CT 06410 U.S.A.
 800-872-5726 (Toll Free), 203-271-1682, 203-271-2596 (Fax)
 www.salsco.com, sales@salsco.com (email)